

Simpler. Faster. More accurate.
Step up to a new level in ICP-MS



Agilent 7500 Series ICP-MS



Agilent Technologies

versatility and flexibility



Make the Change to ICP-MS with Agilent

ICP-MS is widely acknowledged as the premier technique for trace metals analysis. Today's routine lab requires much greater sensitivity than is provided by ICP-OES, and far higher sample throughput than GFAA. ICP-MS meets both these requirements, over a wider analytical working range, and is capable of simultaneously measuring the hydride elements and trace Hg, while adding semiquantitative and isotopic analysis capabilities. ICP-MS is also an extremely powerful and versatile detector for chromatography and laser applications.

But not all ICP-MS instruments are the same. Agilent's new 7500 Series delivers the highest levels of performance, while retaining ease of use, flexibility and reliability through automation and excellence in design. With second generation Octopole Reaction System (ORS) technology and the widest range of sampling accessories, backed by the finest applications and service support, the new 7500 Series is leading the way as labs make the change to ICP-MS.

The updated 7500 Series comprises of two different models, to suit different application requirements and different budgets. Guaranteed expandability and on-site upgradeability means that your investment is protected no matter how your application needs change.

Agilent 7500cx Collision Cell ICP-MS for All Routine Applications

Agilent's unique ORS technology uses helium (He) collision mode to make the new 7500cx the simplest, most flexible, most powerful ICP-MS available. The 7500cx is the clear choice for easy, ppt-level quantification in the most challenging sample matrices.

Universal He collision mode for reliable, predictable removal of all matrix interferences

- Easy setup – no “cookbooks”, no complex optimizations
- Enhanced productivity – no gas mode switching within run
- Improved data confidence in unknown matrices – unlike reactive gases, no new interferences are formed, no analytes or internal standards are lost
- No mathematical correction equations are needed

Designed for high matrix analysis

- 9 orders true linear dynamic range – the largest of any ICP-MS
- Matrix tolerant sample introduction system and interface handles tough samples like wastewaters, soils, foods, biomedical, petrochemical and geological samples with ease

Interference-free semiquantitative analysis – fast!

- He collision mode allows full-scan semiquantitative analysis (Semiquant) of unknowns - with no interferences and all in a single acquisition mode

Optional cell gas lines – reactive gas mode – for special applications

- Optional H₂ reaction mode – enables single digit ppt detection limits for selenium
- Optional Xe reaction mode – enables sub-ppb detection limits for sulfur



Agilent 7500cx

Many companies have already increased productivity and efficiency in their metals lab by replacing multiple techniques with a single Agilent 7500 ICP-MS. This trend has increased with the development of our ORS systems. With the widest dynamic range, coupled with freedom from matrix interferences, Agilent's ORS ICP-MS is replacing ICP-OES, GFAA and other elemental analysis techniques worldwide.



The 7500 Series comprises two models - 7500cx and 7500cs - to meet the dynamic application requirements of today's busy trace metal labs.

Agilent 7500cs The Ultimate Semiconductor Analyzer

ORS technology extends the scope of ICP-MS for semiconductor applications

- Ultra high sensitivity for the ultimate in detection power, featuring the ORS for removal of matrix interferences in the toughest semiconductor sample types
- The interference removal power of the ORS removes even S-based polyatomics in sulfuric acid, uniquely allowing the direct, on-mass measurement of Ti and Zn
- Removal of Ar-based interfering species such as ArO or Ar₂ using H₂ reaction mode
- Unmatched cool plasma performance with Agilent's ShieldTorch interface gives ultimate BECs and complete flexibility for every application
- Optional 3rd cell gas line for NH₃ reaction mode – for ultratrace vanadium measurement in high purity HCl
- Sample introduction system and interface designed for semiconductor use. Special shipping prep and full exhaust ducting for cleanroom use
- New option: Agilent designed PFA inert sample introduction kit

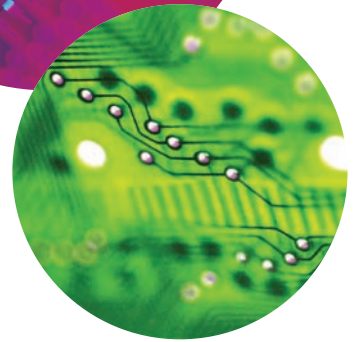
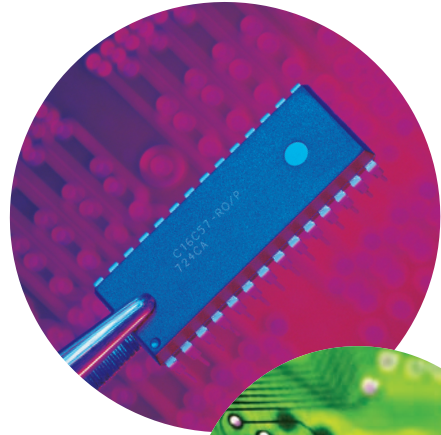

Agilent 7500cs shown with optional I-AS autosampler

analysis without interferences



Collision/Reaction Cell Technology Made Routine

Agilent's ORS has revolutionized collision/reaction cell ICP-MS by bringing effective interference removal capability into the routine analytical lab. The ORS is easy to set up and use for routine trace analysis of complex, variable, and unknown sample matrices, without compromising the multi-element capability of ICP-MS. Analysts familiar with conventional (non-cell) ICP-MS will find the ORS is much simpler to operate.

Uniquely, the ORS removes interferences independently of the analyte (the same cell conditions remove interferences on multiple elements) and independently of the sample matrix (the same cell conditions remove multiple interferences on each element). This means that unknown samples can be analyzed, without requiring matrix-specific or

element-specific optimization, and without requiring any interference correction equations. And unlike other reaction cells, there are no cell scanning voltages to set up or optimize.

The ORS is standard on the 7500cx and 7500cs and available as an on-site upgrade for older non-cell models e.g. 7500a, 7500i. The 7500cx and 7500cs share the same ORS technology, but with different sample introduction systems, interfaces, and ion lenses. These differences address the different requirements of ultratrace analyte measurements in high-purity sample matrices, such as those analyzed in semiconductor labs (7500cs), and of trace and major analyte measurements in complex and variable sample matrices (7500cx).

High transmission octopole

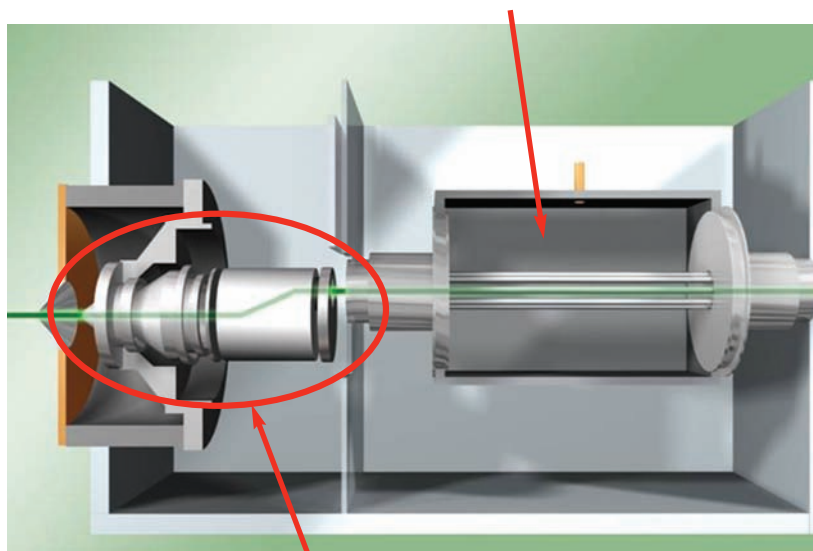

Sample introduction, interface, and ion lens configuration are optimized for appropriate application

Schematic showing ORS featured in 7500cx and 7500cs models. Sample introduction system, interface, and ion lenses are different but are interchangeable between models. Off-axis ion lens can be removed for cleaning without breaking vacuum.

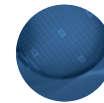
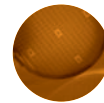

Any Analyte, Any Matrix

In complex and variable sample matrices, the ORS is typically operated in He (collision) mode, using pure He cell gas. This is a major advantage over the use of reactive or mixed cell gases: since He is inert, no new interferences are formed in the cell and no analytes are lost by reaction. The complete absence of new, cell-formed reaction product ions avoids the need for a dynamic, or scanning cell, which means that method setup is simplified and consistent operating conditions can be applied to multiple analytes and multiple sample types. If variable, high-matrix samples are analyzed on a cell system that uses highly reactive molecular gases, the sequential chemistry that is characteristic of these gases will generate many new interferences, the levels of which will vary depending on the levels of other analyte and matrix components present. This inevitably leads to errors in the results.

Screen Uncharacterized Samples with He Collision Mode

In He collision mode, interference removal is not matrix or interference-specific, which also makes He mode a very powerful screening tool, enabling interference-free semiquantitative analysis of unknown, high matrix samples. Freedom from matrix interferences means that semiquantitative data is much more accurate, even in unknown matrices. Interference correction equations are not needed, which in turn means that method setup is simpler and faster and that no analysis time is wasted performing daily checks and adjustments of correction equations.

High Efficiency Reaction Mode

In addition to the wide applicability of the He mode for complex sample matrices and multi-elemental analysis, a few elements have predictable, high intensity plasma-based interferences, which are more efficiently removed using reaction mode. These elements include Ca at its major isotope (m/z 40, which is overlapped by ^{40}Ar) and Se at m/z 78 and 80 (overlapped by Ar_2 polyatomic species). In these cases, H_2 is an ideal reaction gas, since it reacts quickly and efficiently with the Ar-based interfering species, but reacts slowly or not at all with the analyte. Thus, interferences can be reduced to the level of baseline noise, permitting single or sub-ng/L (ppt) detection limits to be achieved for these difficult elements. However, Ca and Se can be also measured at the ppt level in He mode, giving the analyst the option to measure all elements in a single gas mode, reducing analysis time.

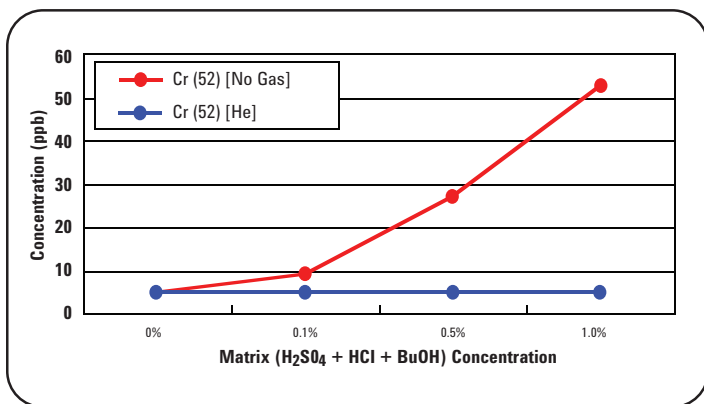

Consistent interference reduction in a variable, complex matrix using He mode. Comparison plots showing no gas mode (red) and He mode (blue) spike recovery data for 5 ppb Cr in a variable matrix (up to 1% each of HCl, H_2SO_4 and Butanol). Potential interferences on ^{52}Cr include ArC , ClOH and SO . All are removed, regardless of reactivity, under a single set of conditions, allowing accurate quantification of Cr at the main isotope, despite the variable matrix composition.

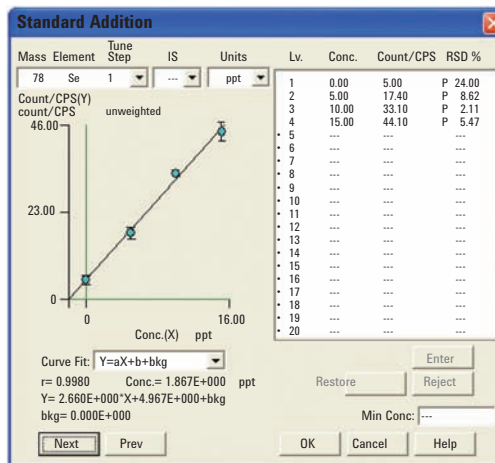

Standard addition calibration of Se using H_2 reaction mode showing good linearity even at 5 ppt. BEC is 1.9 ppt Se. While He collision mode can also be used for trace Se, H_2 mode offers unmatched performance.



Continuous Innovation in ICP-MS

Since the introduction of the highly successful 4500 Series in 1994, Agilent has been responsible for most of the innovation in ICP-MS design, including bench top format, Peltier-cooled spray chamber, cool plasma analysis with ShieldTorch, motorized ICP torch position with autotune, off-axis ion lens, ORS and GC interface.

All of these features come together in the new 7500 Series to deliver the most powerful range of ICP-MS instrumentation ever produced. And we continue to invest and innovate in ICP-MS, to keep our ICP-MS users ahead of their competitors.

1 Open Sample Introduction Area

- Easy access for maintenance and for switching between alternative sample introduction devices.
- High precision, 10 roller peristaltic pump – mounted close to the nebulizer to minimize sample uptake and washout time.

2 Spray Chamber Temperature Control

- Peltier controlled spray chamber prevents drift due to lab temperature change and reduces oxide formation. Compatible with both quartz and inert spray chambers.
- Enables routine analysis of volatile organic sample types, without requiring an additional mini-chiller.

3 Robust Plasma

- Maintenance-free, solid state RF generator. Unique digital-drive for highest coupling efficiency.
- 27.12MHz RF produces a more robust plasma for complete decomposition of sample matrix, giving low oxide and other matrix interferences.
- High precision, motorized, auto-alignment of ICP torch position with full autotune.

4 Agilent ShieldTorch System

- ShieldTorch System (STS) controls ion energies for increased sensitivity and improved interference removal in ORS collision mode, using energy discrimination.
- STS enables cool plasma mode for semiconductor applications, including high purity organic solvents.

5 Interface and Ion Lens

- Extraction lenses and off-axis ion lens system ensure high ion transmission across the entire mass range.
- Off-axis lens located before the gate valve in ORS systems: protects cell from contamination and can be cleaned without breaking vacuum.

6 Active Mass Flow Control (AMFC)

- Agilent designed AMFC system precisely controls all standard gas flows (4 argon gas, and 2 cell gas flows in ORS systems) using sophisticated electronic pressure sensors.

7 Octopole Reaction System

- Collision/reaction cell for highly efficient removal of polyatomic interferences. Unique He collision mode for reliable analysis of unknown sample matrices. H₂ reaction mode for semiconductor applications and ultimate Se DLs.

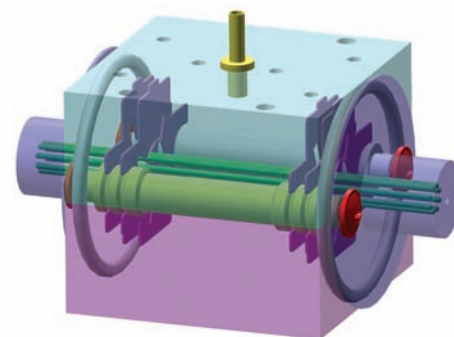

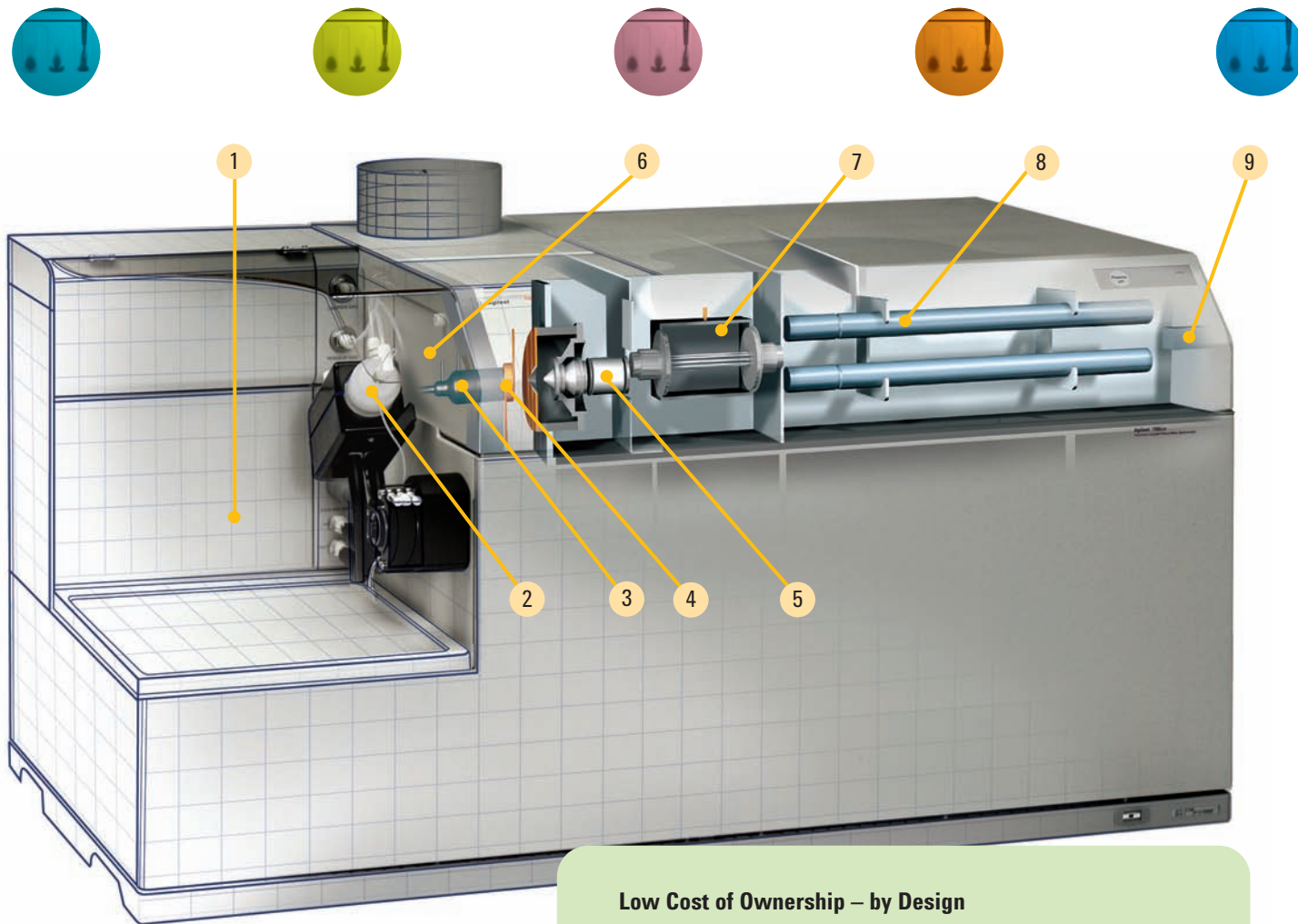

8 Vacuum System and Analyzer

- High frequency 3MHz quadrupole with unique true hyperbolic cross section rods for superior abundance sensitivity and peak separation.
- Single split flow turbo pump backed by single rotary pump.

9 Advanced Detection System

- Simultaneous pulse/analog detector with fully automated calibration. High speed analog mode for transient signals.
- Unique log amplifier provides nine orders of dynamic range. Maximum measurable concentration >1000ppm.

Low Cost of Ownership – by Design

The 7500 Series has been designed for maximum reliability and uptime in routine use, even in the toughest lab environments. The extremely low failure rate allows us to price our support contracts equally low, and in combination with high uptime and high sample capacity, makes the 7500 Series the most profitable ICP-MS to own.

- Agilent ICP-MS are manufactured at ISO 9001 and ISO 14001 certified facilities.
- Extremely high build quality with all stainless steel chassis.
- Extensive shock, vibration, heat and humidity testing at production prototype stage - means optimum performance is guaranteed over a wide temperature/humidity range.
- Solid state RF generator is maintenance-free - no RF tubes to replace.
- Ion lens can be cleaned without breaking vacuum on ORS models.
- Predictive maintenance software ensures optimum performance.
- Advanced diagnostic tools enable easy fault finding, and modular design means fast fix times.



Expanding Applications

Agilent has the widest range of sampling accessories to further enhance productivity and expand the applicability of the 7500 Series.

Agilent Integrated Autosampler (I-AS)

The I-AS is a fully integrated, covered autosampler for ultratrace analysis. Designed for semiconductor and other ultratrace applications and for when sample volume is limited. Maximum capacity 89 samples.

ASX-500 Series Autosampler

A high capacity autosampler suitable for high throughput labs. Maximum capacity 360 samples. Fully supported by Agilent.

Inert Sample Introduction Kit

The kit consists of an inert end cap, ultrapure polymer spray chamber and demountable HF resistant torch with sapphire or platinum injectors for minimum sample contamination.

Integrated Sample Introduction System (ISIS)

ISIS features two high precision pumps and up to two six-port switching valves, enabling constant flow nebulization, autodilution (with Intelligent Sequencing software), discrete sampling and matrix elimination. Hydride generation is also available.

GC-ICP-MS Interface

Programmable heated interface for GC-ICP-MS. Interface can be heated to 300 deg.C for high boiling point compounds. Unique torch design eliminates connections and avoids cold spots.

LC-ICP-MS Interface and Speciation Kit

All necessary tubing, connections and cables to enable fully automated LC-ICP-MS. Special ICP torch for organic mobile phases. Arsenic speciation kit – includes column and methodology to measure As species in urine.

Laser Ablation

Laser ablation ICP-MS is a widely used technique for the direct analysis of solid samples. The 7500 Series' excellent sensitivity, high speed simultaneous detector and 9 orders dynamic range makes it perfectly suited to laser ablation analysis.

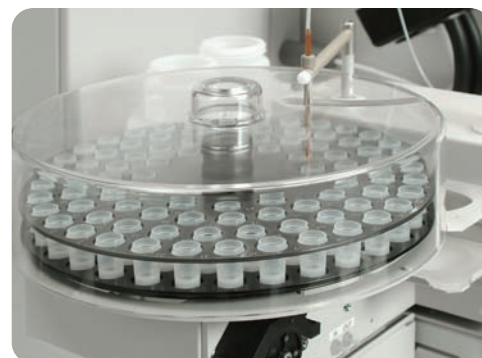

Agilent Integrated Autosampler



Integrated Sample Introduction System



Laser ablation



Opening up the World of Elemental Speciation Measurement

Combining Chromatography and ICP-MS for Elemental Speciation Analysis

In the environmental, biomedical, food, pharmaceutical, and petrochemical industries, it is becoming much more important to be able to determine not just the total amount of an element, but also its chemical form, since this can have a dramatic impact on the element's bioavailability, mobility, toxicity and other chemical properties. Combined with various chromatographic separation techniques, ICP-MS is now recognized as the most versatile and powerful tool for elemental speciation analysis.

As a leading supplier of GC, LC and CE as well as ICP-MS, Agilent is leading the way with routine hyphenated solutions and supporting the rapid growth in speciation measurement worldwide. Agilent developed the first commercial GC-ICP-MS interface in 2001, featuring a heated transfer line capable of handling high boiling point compounds. Also available is an LC-ICP-MS Connection Kit and complete analytical solutions such as the Arsenic in Urine Speciation Kit. Agilent's expertise in separation techniques ensures seamless installation and implementation of these hyphenated systems.

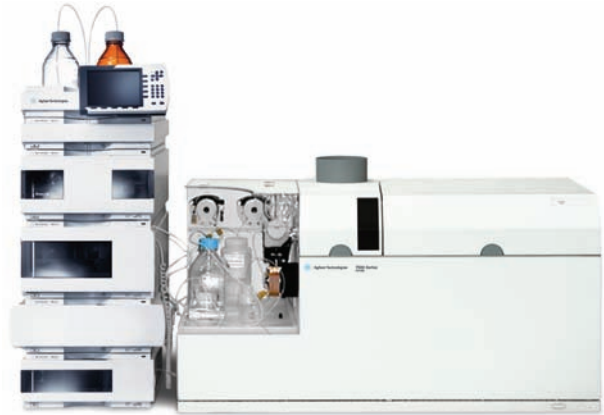

LC-ICP-MS combines the 1200 Series LC with the 7500 ICP-MS.

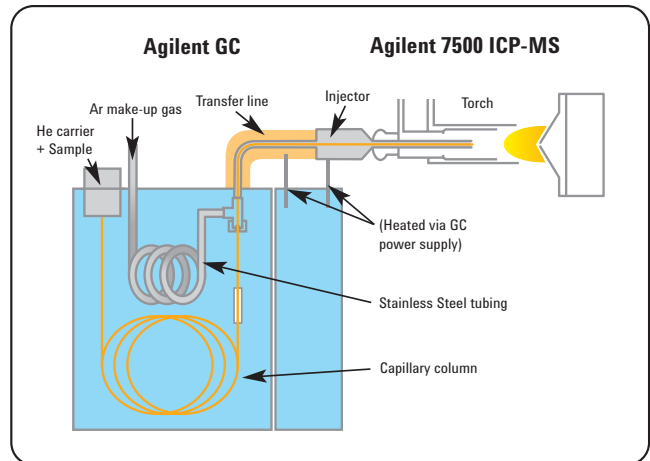

GC-ICP-MS system diagram



7500 ICP-MS with Agilent GC

productivity through automation



ICP-MS ChemStation Software – Intuitive. Flexible. Powerful.

The ChemStation software controls all instrument operations from setup and optimization to final reporting. The modern graphical user interface operating under Windows XP allows quick and intuitive operation. Context-sensitive help is always just a click away.



Top level layout is user configurable and includes all relevant programs from instrument control to data analysis

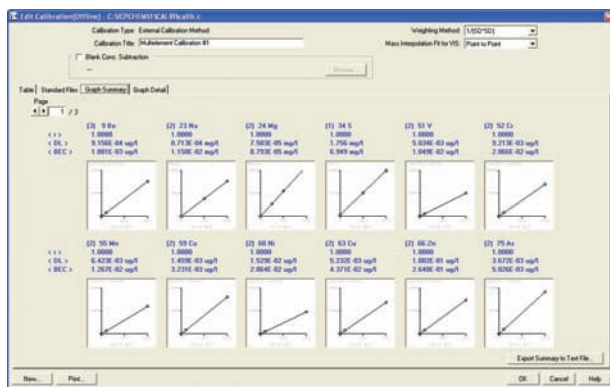

Flexible calibration plot and DL display and output

Simple Start-up

Prepare the 7500 for analysis simply by clicking the "ON" button – The sequence of plasma initiation events is fully automated and documented on screen.

Intelligent Automation

The Agilent 7500 Series provides full system control to ensure that optimum and consistent operating conditions are maintained. Sophisticated autotuning ensures consistent operation independent of operator expertise.

Easy Method Setup with Method Wizard

The Method Wizard guides inexperienced users through the process of creating a new method, providing regulatory compliant, preconfigured templates for common applications.

Flexible Data Acquisition

The 7500 Series can acquire data for a given sample in several gas modes. The software allows data from a single sample to be acquired automatically in multiple modes, with the results combined into a single report.

Data Processing and Reporting

ChemStation allows complete flexibility for post-run data reprocessing, including the ability to change internal standards, curve fits, and even report formats. Virtual Internal Standardization allows the user to create a mass-interpolated internal standard. Flexible, open architecture and a powerful macro language allow connectivity to LIMS systems.

Intelligent Rinse Functions

Pre-emptive and Intelligent Rinse functions insure highest possible throughput and eliminate the risk of carryover from dirty samples. Pre-emptive rinse begins rinsing the autosampler probe and tubing prior to the end of acquisition using the sample remaining in the introduction system to complete data acquisition. Intelligent Rinse continuously monitors carryover and extends the rinse time only as needed.

Automatic Shutdown

A series of built-in hardware and software interlocks continually monitor instrument parameters ensuring safe and intelligent unattended operation and fail-safe shutdown.

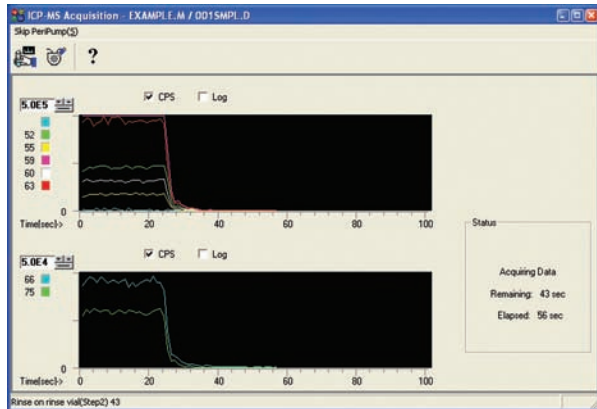
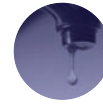

Intelligent Rinse and Pre-emptive rinse improve sample throughput

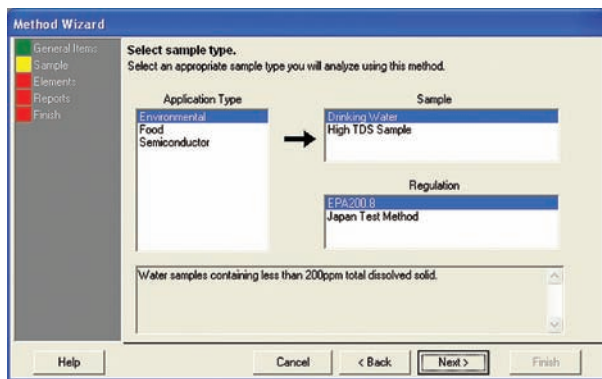

Method Wizard guides the user through setup of common applications with predefined templates

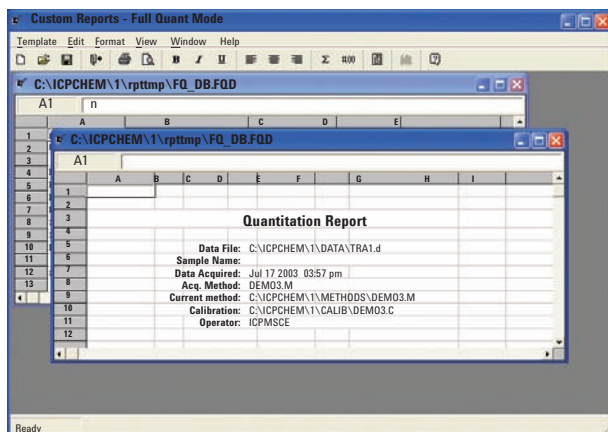

Custom reports templates are created by a simple drag-and-drop operation in a spreadsheet format

Optional Software

Optional software seamlessly integrates with the ChemStation to extend the capabilities of the Agilent 7500 ICP-MS to new applications and analytical requirements.

Intelligent Sequencing provides the ultimate in QA/QC software functionality. Intelligent Sequencing takes control of run-time quality assurance by evaluating data quality in real-time, comparing measured results against expected values and taking appropriate and flexible QC actions as a result. The software is delivered with a set of preconfigured templates that allow users to meet US EPA 200.8, 6020 and other internationally regulated requirements. It can be easily tailored to meet laboratory specific QA/QC requirements, allowing users to produce their own protocols by adding customized quality control samples and criteria.

Plasma Chromatographic Software seamlessly integrates chromatographic data analysis with ICP-MS sequencing detection creating a truly hyphenated system. It features powerful integration, calibration and quantification capabilities for handling chromatographic data. It enables the user to set up fully automated sample sequences for chromatography-ICP-MS runs with real-time data acquisition and analysis. Since it works in real time, Plasma Chromatographic Software can perform real time QC actions, such as recalibration of retention times, response factors and isotope ratios. Plasma Chromatographic software supports additional data file formats including Agilent GC/MS and industry standard AIA format and can export data in AIA and CSV formats allowing powerful integration of multiple techniques.

User Access Control Pack is optional security and log history software, designed primarily for laboratories needing to comply with strict regulatory standards. It provides configurable user access to various ChemStation functions and maintains a secure log of all user access.

Premier Service and Applications Support

The design, manufacturing and component-part standards of the 7500 Series are of the highest order, making our instruments extremely reliable and easy to use. But when you need support – with hardware, software or applications, a global network of factory-trained ICP-MS specialists is there to help you. Agilent provides the widest variety of support and training options to meet your requirements and to ensure you get the most from your ICP-MS.



Training

Familiarization training is provided at installation, along with comprehensive manuals and a **maintenance video DVD**. Agilent also offers training classes worldwide and onsite applications consulting for fast implementation. Our regular e-seminars on instrument operation are an efficient way to keep up to date.

Agilent ICP-MS Journal User Newsletter

The Agilent ICP-MS Journal is published 4 times per year and is a great source of information on ICP-MS. The Journal features technical articles, user contributed articles and information on instrument operation, support and upgrades.

Agilent ICP-MS Web site

Go to www.agilent.com/chem/icpms to find an array of ICP-MS services and the most comprehensive collection of literature and information – all freely downloadable, including:

- ICP-MS and other Agilent product information
- Agilent e-Seminars, user meetings and other events
- Application notes, posters, technical notes, back issues of the Agilent ICP-MS Journal, and other useful literature
- Extensive technical support tools

Register at:

www.agilent.com/chem/registration and select ICP-MS as your area of interest to receive e-mail notification of new additions to the ICP-MS website and upcoming events.

Agilent ICP-MS User Forum

Users of Agilent ICP-MS are encouraged to join the ICP-MS Forum – an on-line discussion group exclusively for Agilent users wishing to ask questions and share their experience and expertise in ICP-MS. Sign up at www.agilent.com/chem/icpms

For more information

For more information about the Agilent 7500 Series ICP-MS or other Agilent products and services, visit us online or call toll free:

www.agilent.com/chem/icpms

1-800-227-9770 (in the U.S. and Canada)

In other countries, please contact your local Agilent Representative or Agilent Authorized Distributor.

The 7500cx can not be used with hydrogen cell gas or hydrogen cell gas mixtures unless the optional hydrogen cell gas line is installed.

Agilent 7500 Series ICP-MS are manufactured at an ISO 9001 and ISO 14001 certified facility.

Microsoft® is a U.S. registered trademark of Microsoft Corporation. Windows XP is a U.S. registered trademark of Microsoft Corporation.

Information, descriptions, and specifications in this publication are subject to change without notice.

© Agilent Technologies, Inc. 2007

Printed in the U.S.A. June 21, 2007

5989-6410EN



Agilent Technologies